

STANDARD MATERIALS AND CONSTRUCTION

FRAME: .125" thick (nominal) extruded aluminum, 6063-T52/T6 alloy.

BLADE: .125" thick (nominal) extruded aluminum, 6063-T52/T6 alloy. Blades are at 35°/42° angle and approximately 4½" on centers.

LOUVER FACE: Full width sill, with blades and head contained in jambs.

SCREEN: (When indicated.)

½" flattened aluminum (.051" thick),

-or- ½" sq. mesh, intermediate double-crimped aluminum wire, .063" dia.,

-or- 19/16 mesh, .011" dia. aluminum wire, insect screen.

FINISH: Mill

OPTIONS

Finish - Baked Enamel, Kynar, Anodize

NOTES

1. Nominal deductions will be made to the opening size given.
2. Approximate shipping weight is 4.0 lbs./sq.ft.

LOUVER SIZES

Min Panel	Max Single Panel
12"W x 12"H	60"W x 96"H

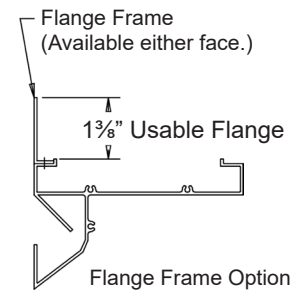
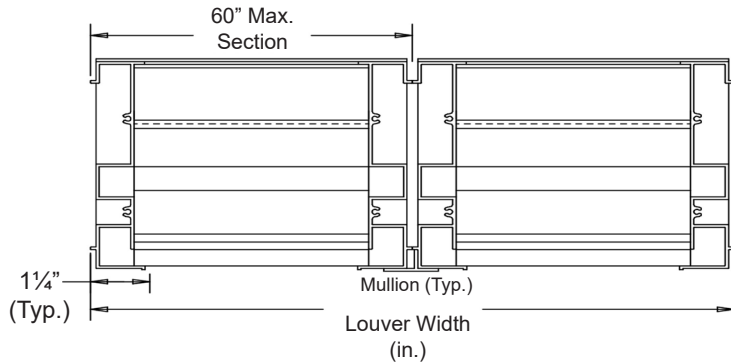
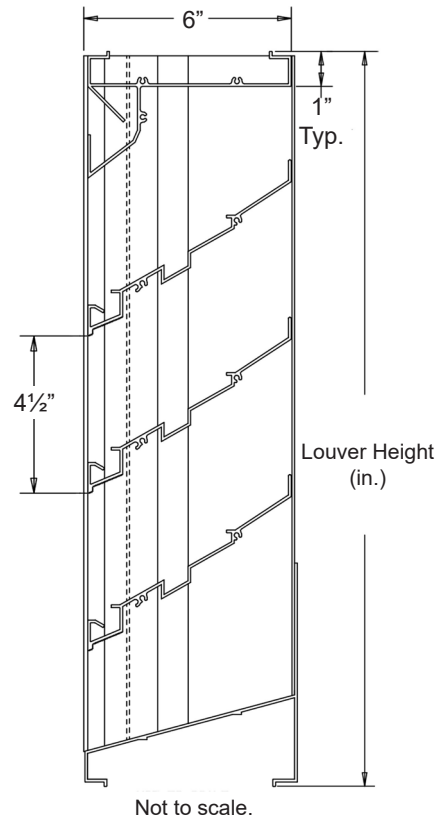

													
Item #	Qty	Width	Height	Width	Height	Mullion	Type	Location					Union Made
Arch. / Eng. :		Opening Size		Louver Size		EDR:	ECN:		Job:				
Contractor:													
Project:						Date:		DWN:		DWG:			

PERFORMANCE DATA

Pressure Drop: .12 in. w.g. at 1000 fpm (Intake)
 Free Area: 8.91 sq.ft. = 56% for 48"W x 48"H sample tested in accordance with AMCA Standard 500-L.
 Beginning Point of Water Penetration: 993 FPM

Ratings do not include effects of a screen.

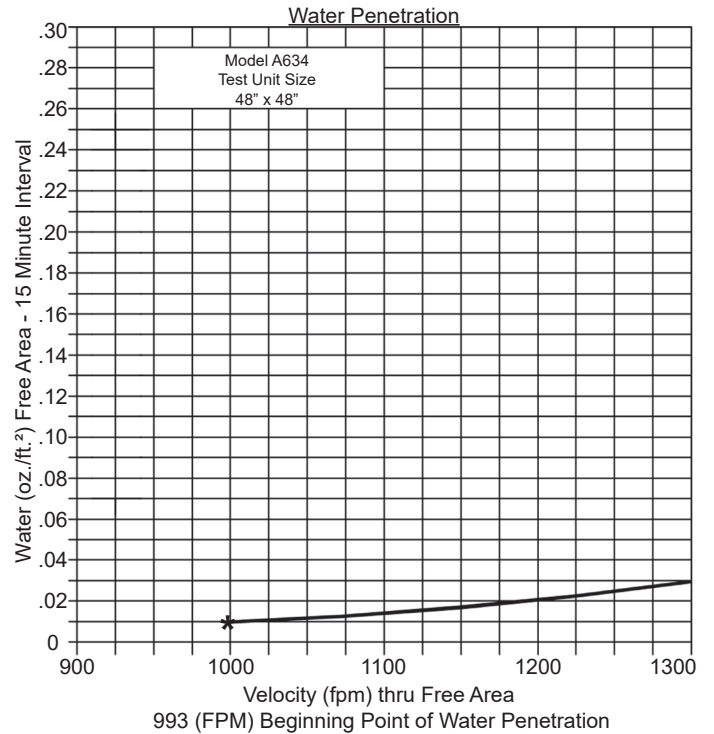
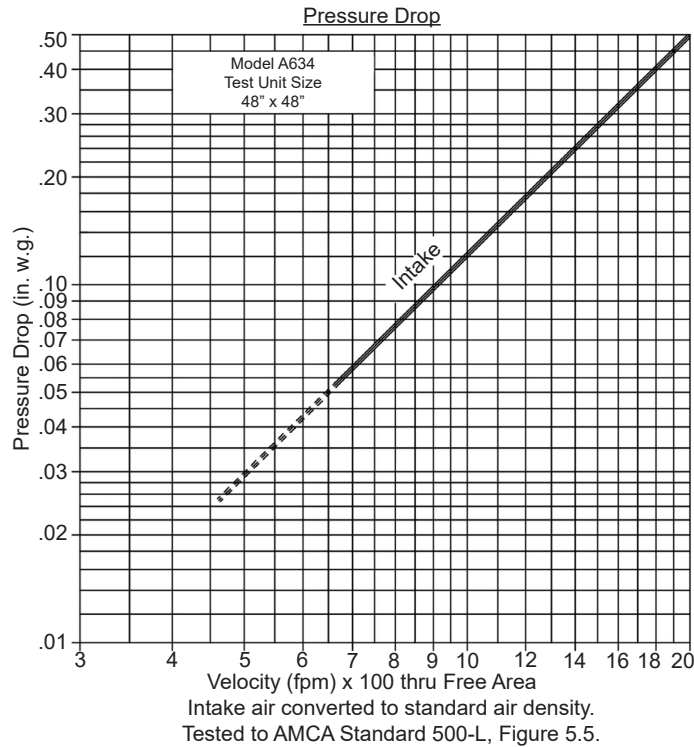

		Free Area (sq.ft.)								
		Width (in.)								
		12"	18"	24"	30"	36"	42"	48"	54"	60"
Height (in.)	12"	.25	.41	.57	.72	.88	1.04	1.20	1.36	1.51
	24"	.78	1.27	1.76	2.25	2.74	3.23	3.72	4.21	4.70
	36"	1.29	2.11	2.92	3.74	4.55	5.37	6.18	7.00	7.81
	48"	1.83	2.99	4.15	5.31	6.47	7.62	8.91	9.94	11.10
	60"	2.36	3.85	5.34	6.83	8.32	9.81	11.30	12.79	14.28
	72"	2.87	4.69	6.50	8.32	10.13	11.95	13.76	15.58	17.39
	84"	3.42	5.57	7.73	9.89	12.05	14.21	16.36	18.52	20.68
	96"	3.94	6.43	8.92	11.41	13.90	16.39	18.88	21.37	23.86



Air Balance certifies that the Model A634 shown herein is licensed to bear the AMCA seal. The ratings shown are based on tests and procedures performed in accordance with AMCA Publication 511 and comply with the requirements of the AMCA Certified Ratings Program. The AMCA Certified Ratings Seal applies to Water Penetration and Air Performance Ratings only.